

SMALL PRESSURE CONTROLS (DISC TYPE)

High Volume OEM Item

Type ACB & LCB

SAGInoMIYA

GENERAL DESCRIPTION

- Pressure Control CB series are disc type small pressure controls featuring compact structure and field proven high quality.
- It is designed to suit modern designed application with its compact and various type of connection styles, such application as air conditioning, automobile industries and others.

Type ACB···High & medium pressure range

Type LCB···Low pressure range

CE mark applicable (available upon request for Type ACB & Type LCB)

UL recognized (available upon request for Type ACB)



Type ACB, LCB



Type ACB, LCB

SPECIFICATIONS

- Ambient temperature: -30 to 100°C

STANDARD TYPE NUMBER SELECTION

Type ACB & LCB

Unit: MPa {kgf/cm²}

Catalog No.	Contact Functions	Range		Max. Pressure	Pressure Connections	Terminal Construction (DIMENSION)	Application	Wt. (kg)
		Off	On					
ACB	SPST (High Cut) (A)	4.2 {42}	3.3 {33}	4.5 {45}	1/4" Solder OR Female Flare	Open(①・③) OR Water Proof (②・④)	High Pressure Cut Out	Open (0.03) Water Proof (0.06)
		3.1 {31}	2.4 {24}					
		2.8 {28}	2.2 {22}					
		2.6 {26}	2.1 {21}					
		2.3 {23}	1.8 {18}					
	SPST(High Cut) + Manual Reset (B)	2.8 {28}	2.1 {21}			Water Proof(⑤)		0.06
		2.6 {26}	2.0 {20}					
		2.3 {23}	1.8 {18}					
	SPDT (C)	2.8 {28}	2.2 {22}			Open(⑥) OR Water Proof(⑦)		Open (0.03) Water Proof (0.06)
		2.6 {26}	2.1 {21}					
		2.3 {23}	1.8 {18}					
	SPDT + Manual Reset (D)	2.8 {28}	2.1 {21}			Water Proof(⑧)		0.08
2.6 {26}		2.0 {20}						
2.3 {23}		1.8 {18}						
LCB	SPST (Low Cut) (E)	0.22 {2.2}	0.36 {3.6}	1.5 {15}		Open(①・③) OR Water Proof (②・④)	Low Pressure Cut Out	Open (0.03) Water Proof (0.06)
		0.17 {1.7}	0.27 {2.7}					
		0.07 {0.7}	0.17 {1.7}					
		0.05 {0.5}	0.15 {1.5}					

ELECTRICAL RATINGS

Type ACB & LCB

Category of Ratings			M Rating			L Rating			T Rating
Rated Current (A)	Rated Voltage (V)	Power Factor (cos φ)	125V.AC	250V.AC	12V.DC	125V.AC	250V.AC	12V.DC	12/24V.DC
	Non-Inductive Current		1	1 to 6	1 to 4	1 to 4	0.02 to 2	0.02 to 1	0.05 to 0.1
Full Load		0.75	—			—			
Inductive Current	Inrush Current	—	1 to 24	1 to 16	—	0.02 to 8	0.02 to 4	—	—

CONTACT FUNCTIONS

Type ACB & LCB

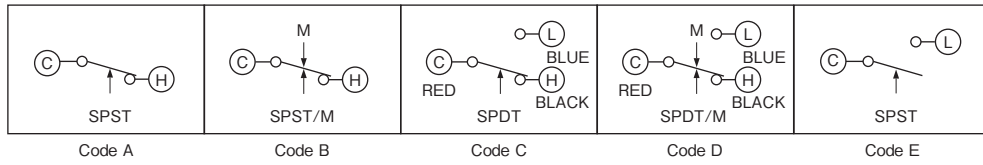

↑ : Operating direction on press. increase at High Press.Side
 M ↓ : Operating direction on manual reset

PRESSURE CONNECTIONS

Unit: mm

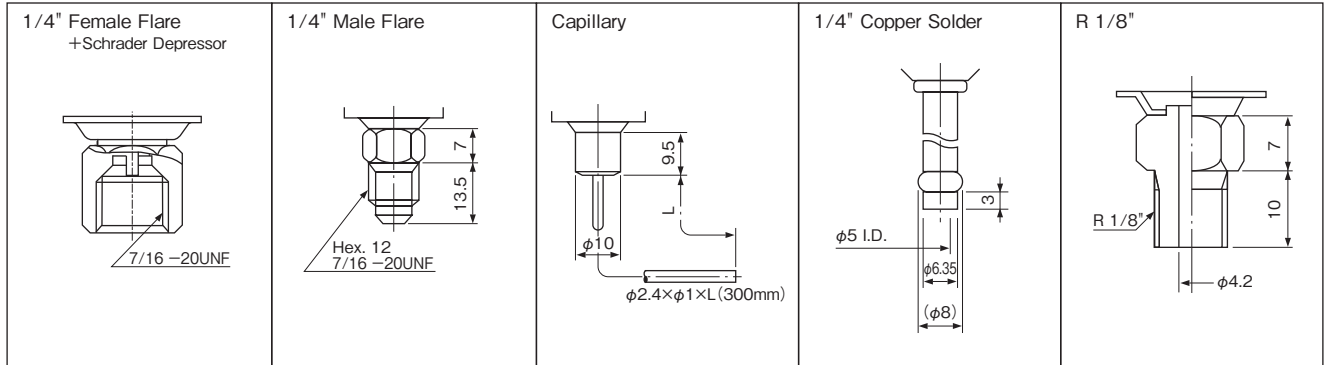

DIMENSIONS

Unit: mm

