

CO₂ REFRIGERANT APPLICATIONS

High Volume OEM Item

Type CCB, HSK, HPV, UKV-J & JKV

SAGInoMIYA

GENERAL DESCRIPTION

- Used for CO₂ refrigerant applications.
- Available for extreme high pressure.
- Application: Bottle cooler, display case, heat pump water heaters, vending machine



Type CCB



Type HSK



Type HPV



Type UKV-J

● PRESSURE CONTROL for High Pressure [Type CCB]

SPECIFICATIONS

Unit: MPa {kgf/cm²}

Catalog No.	Setting		Max. Pressure	Contact Function	Pressure Connection	Terminal Construction	Application	Wt. (kg)
	on	off						
CCB- * * * *	10 {100}	15 {150}	15 {150}	SPST (High Cut)	1/4" Solder	Open	High Pressure Cut Out	0.07

• Allowable fluid temperature: -30 to 100 °C

ELECTRICAL RATINGS

Category of Ratings			T Rating		M Rating	
Rated Current (A)	Rated Voltage (V)	Power Factor (cos φ)	24V. DC	12V. DC	120V. AC	240V. AC
	Non-Inductive Current		1	0.01 to 0.05		1 to 6
Inductive Current	Full Load	0.75	-	-	-	-
	Inrush Current	-	-	-	-	-

CONTACT FUNCTION

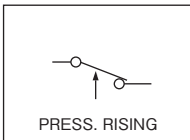

DIMENSIONS

Type CCB

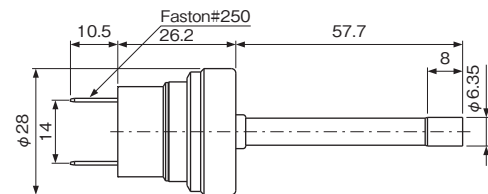

Unit: mm

● PRESSURE SENSOR for High Pressure [Type HSK]

SPECIFICATIONS

Unit: MPa {kgf/cm²}

Catalog No.	Pressure Range	Supply Voltage	Output	Accuracy	Current Consumption	Load Resistance	Airtight Pressure	Pressure Connection	Wt. (kg)
HSK-BC150D- * * *	{0 to 150} 0 to 15	5V. DC±0.25V	0.5 to 4.5V. DC	±2.5% F.S.	Max. 10mA	Min. 10kΩ	15 {150}	φ6 Solder	0.07

• Allowable fluid temperature: -30 to 120 °C

• Ambient temperature: -30 to 100 °C

WIRING

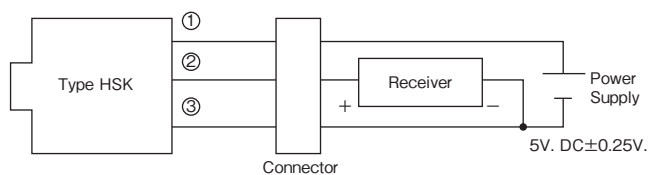

DIMENSIONS

Type HSK

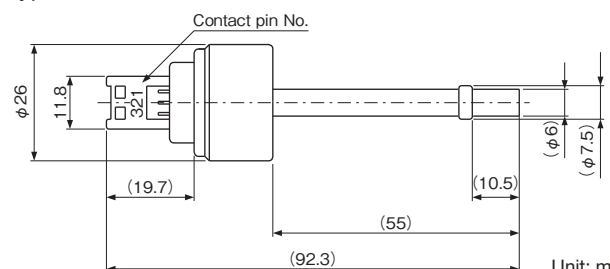

Unit: mm

● SOLENOID VALVE for High Pressure [Type HPV]

TYPE NUMBER SELECTION (SPECIFICATIONS)

Unit: MPa {kgf/cm²}

Catalog No.	Port Size (mm)	Cv Value	Connection		O.P.D.		Max. Working Pressure	Operation	Wt. (kg)
			Copper Tube O.D.	Style	Min.	Max.			
HPV-102DQ1	1.0	0.028	1/4"	Solder	0	10.0 {100}	13.0 {130}	Normal close	0.05
HPV-122D	1.2	0.038							0.09
HPV-402DQ3	4.0	0.32	1/4"		0				0.09
HPV-825DS	7.8	0.54	5/16"		0.1{1}				0.13

- O.P.D.: Operating Pressure Differential (by air pressure)
- Ambient temperature: -20 to 50 °C
- Allowable fluid temperature: -30 to 120 °C

ELECTRICAL RATING OF SOLENOID COILS

Valve Type	Rated Voltage		Tolerance (%)	Voltampere		Power Consumption (W)	Insulation Class	Wt. (kg)
				Running	Inrush			
HPV-102DQ1	100V. AC	50/60Hz	±10	11/8	32/27	6/4.5	* Class B Molded	0.13
HPV-122D	200V. AC			16/13	52/38	9/8		0.16
HPV-402DQ3	200V. AC			10/8	32/26	5.5/4.5		0.16
HPV-825DS				14/11	42/33	7/6		0.20

* IEC compliance

DIMENSIONS

Type HPV-102DQ1 {HPV-122D}

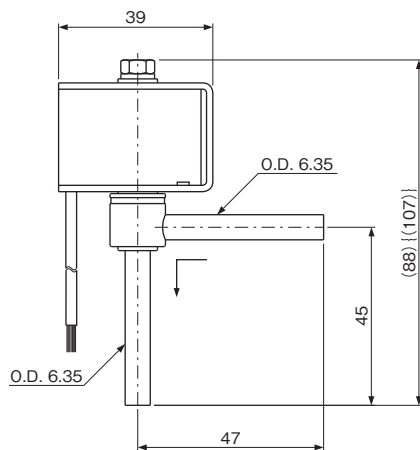

Type HPV-402DQ3

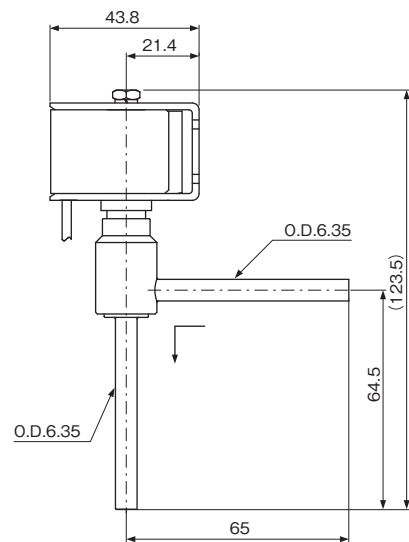

Please contact us if other connection are required.

Type HPV-825DS

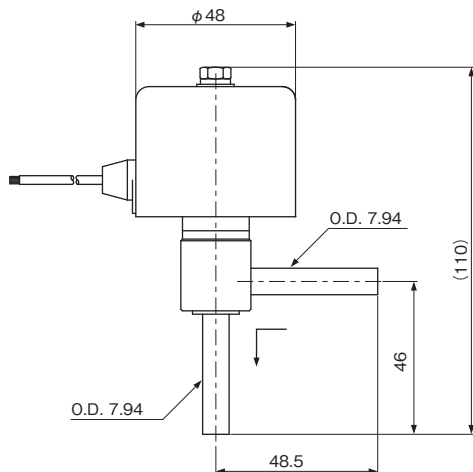

Unit: mm

● ELECTRONIC EXPANSION VALVE for High Pressure [Type UKV-J, JKV]

TYPE NUMBER SELECTION (SPECIFICATIONS)

Unit: MPa {kgf/cm²}

Catalog No.	O PULSE FLOW	Port Size (φ mm)	Cv Value	Capacity (U.S.R.T) {kW}		Max. Working Pressure	Operating Pressure Differential	Connection (Solder) (mm)		Wt. (kg)	
				*1 R744 (CO ₂)	*2 R744 (CO ₂)			B side	A side		
UKV-J14D	OPEN TYPE	1.4	0.056	2.9 {10.3}	3.9 {13.6}	15 {150}	0 to 10 {0 to 100}	φ 6.35 OD	φ 6.35 OD	0.05	
	CLOSE TYPE										
JKV-20D	OPEN TYPE	2.0	0.12	6.2 {21.9}	8.2 {29.0}			φ 7.94 OD	φ 7.94 OD		0.2
	CLOSE TYPE										
JKV-24D	OPEN TYPE	2.4	0.17	8.7 {30.7}	11.6 {40.7}			φ 7.94 OD	φ 7.94 OD		
	CLOSE TYPE										

* 1: CT = -5 °C, ET = -25 °C, SH = 0 °C, SC = 0 °C

* 2: Gas cooler inlet temp. = 70 °C, Gas cooler outlet temp. = 22 °C, ET = 6 °C, SH = 0 °C

• Allowable fluid temperature: -30 to 70 °C

• Ambient temperature: -30 to 70 °C

SPECIFICATIONS OF COIL

Valve Type	Excitation method	Rated Voltage & Current	Insulation Class	Wt. (kg)
UKV-J14D	1-2 Phase excitation	12V. DC. 260mA/Phase	* Class E Molded	0.13
JKV-20D				0.14
JKV-24D		12V. DC. 380mA/Phase		0.19

* IEC compliance

DIMENSIONS

Type UKV-J

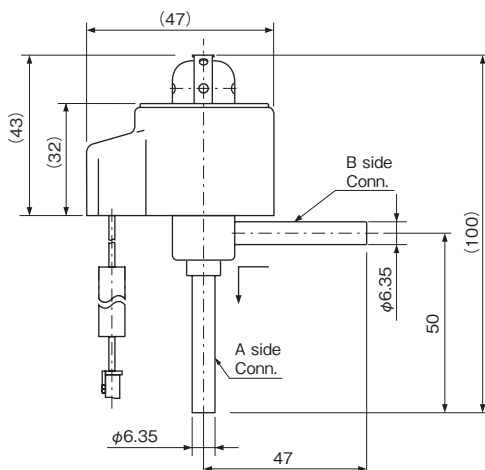

Type JKV-20D

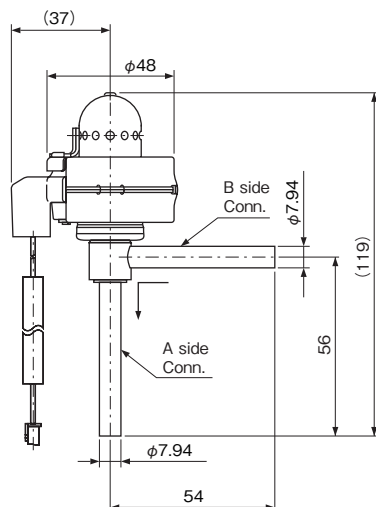

Type JKV-24D

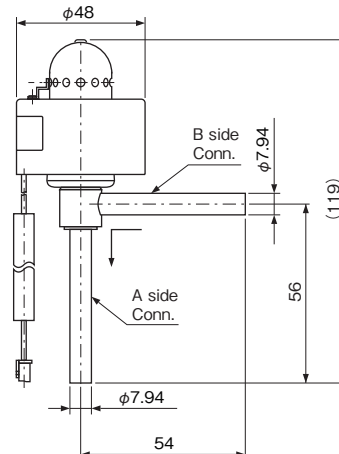

Unit: mm