

ROOM HUMIDISTATS

Type **AHS**

SAGInoMIYA

GENERAL DESCRIPTION

- Accurate humidity control assured by nylon ribbon.
- Used for low or line voltage.
- Easy adjustment by dial knob.
- Dial stopper screw prevents unauthorized change of setting.



SPECIFICATIONS

Unit: % RH

Catalog No.	Contact	Range		Differential	Ambient Temp. on Use (°C)	Wt. (kg)
		Min	Max.			
AHS-C1090	SPDT	30	90	Approx. 5	10 to 40	0.17

ELECTRICAL RATINGS

Rated Current (A)		Rated Voltage (V)	Power Factor (cos φ)	125V. AC	250V. AC	24V. DC
Non-Inductive Current		1.0	—	4.5	2	1
Inductive Current	Full Load	0.75	—	3	1.5	0.4
	Inrush Current	—	—	12	6	2

Minimum Contact Capacity: 50mA

CONTACT FUNCTIONS

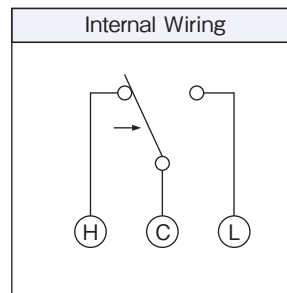

DIMENSIONS

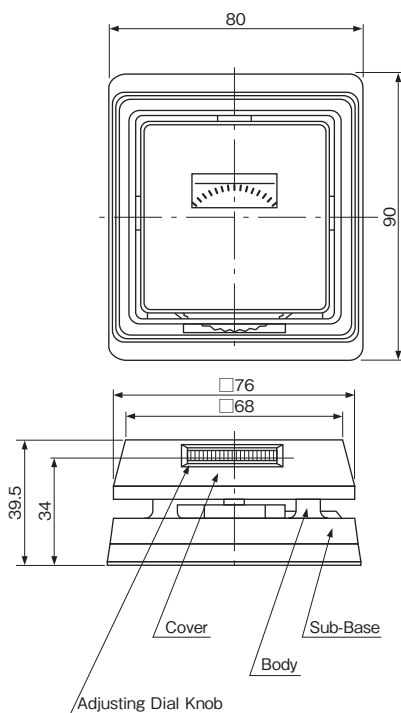

Unit: mm

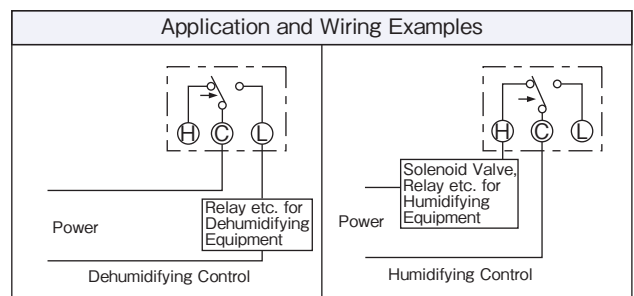

Arrow mark indicates humidity increase.